

# The Influence Of Work Discipline And Work Performance On Employee Performance Through Organizational Culture As An Intervening Variable In The Work Unit Of The Pamekasan Regency Transportation Office

Original Article

**Teguh Isgunanto<sup>1\*</sup>, Sutoyo<sup>2</sup>, Lintang Suminar<sup>3</sup>, A'isy Fiklik Nafisah<sup>4</sup>, Yosa Endriatmoko<sup>5</sup>**

<sup>1\*-5</sup>Master of Management study program, Sekolah Tinggi Ilmu Ekonomi Artha Bodhi Iswara, Indonesia  
Email: <sup>1\*</sup> [teguhsegara91@gmail.com](mailto:teguhsegara91@gmail.com)

Received: 27 October 2025

Accepted: 6 November 2025

Published online: 7 November 2025

## Abstract

Human resources or employees are the key to determining the success of an organization, so that every employee is not only required to have knowledge, skills, and abilities, but also must have experience, motivation, self-discipline, and high work spirit. So that if employee performance is good, the organization's performance will increase, leading to the achievement of desired goals and objectives. The success of an organization is judged by the success of the organization in achieving goals and objectives as well as the achievement of vision and mission. The first reason is because both the direct and indirect influence of Employee Performance shows a significant influence. Both indirect coefficients of influence have a value smaller than the direct path coefficient ( $0.233 < 0.767$ ). This states that the higher the work discipline and work achievement, the more employee performance increases with the increase in organizational culture.

**Keywords:** Work Discipline, Work Performance, Employee Performance, Organizational Culture.

## 1. Introduction

In the face of a modern era full of challenges, human resource management plays a very important role in the survival of the organization. Every company must be committed to continuing to develop the quality of its human resources to compete and maintain a positive image in the eyes of the public. As the main manager of the workforce in various departments, the HR management function is central in supporting organizational productivity. According to (Sutiawan, 2021), internal human resource development contributes to improving careers, services, morale, and job satisfaction, in addition to being able to reduce the rate of work accidents and strengthen organizational performance. Thus, the success of an organization is greatly influenced by the quality and performance of its employees, who must have high competence, experience, motivation, and work ethic for the organization's vision and mission to be optimally achieved.

Employee performance is a crucial factor in the success of organizational operations. Tegar (2019:70) defines performance as the result of individual work based on ability, experience, seriousness, and punctuality in completing tasks. According to him, three main factors affect performance, namely ability and interests, clarity of task delegation, and work motivation. In an effort to improve performance, companies generally conduct evaluations through performance appraisal procedures. This study highlights four main factors that affect



performance, namely discipline, organizational commitment, leadership, and accountability. (Hasibuan, 2019:193) emphasized that discipline is a vital function in HR management because increasing work discipline can encourage improved employee performance. The findings of (Triana et al., 2020) also show that there is a positive and significant relationship between work discipline and employee performance.

In addition to discipline, organizational commitment also plays an important role in performance. (Sitompul, 2021) states that structured and focused training can help employees develop their careers, which in turn improves job satisfaction and performance. Workers with high organizational commitment tend to have moral and ethical responsibilities in carrying out their duties. The research of (Frans and Darna, 2020) also strengthens this finding by stating that organizational commitment has a positive and significant effect on work performance. Another factor that also affects performance is leadership. (Suwatno and Priansa, 2019:139) explained that leadership has a strategic function in determining employee achievements. A leader who is able to be an example and direct his subordinates effectively will strengthen organizational performance, as evidenced by (Musfawati, 2019) who found that leadership has a positive effect on work performance.

The fourth factor that is no less important is accountability. Sedarmayanti in (Febriani et al., 2019) defines accountability as the obligation of individuals or organizations to account for their performance and actions to the authorities. Accountability plays an important role in realizing transparent and results-oriented organizational governance. (Jufrizen's, 2020) research shows that company culture has a positive effect on employee performance, while (Siregar et al., (2020) added that work culture has a significant impact on employee welfare. In the context of the Pamekasan Regency Transportation Office, the performance of members of the Transportation Department is still not optimal, mainly due to low discipline and lack of commitment in carrying out their duties. Therefore, this study focuses on efforts to increase employee productivity with the title "The Influence of Work Discipline and Work Achievement on Employee Performance Through Organizational Culture as an Intervening Variable in the Work Unit of the Pamekasan Regency Transportation Office."

## **2. Literature Review**

### **2.1. Human Resource Management**

Human resource management (HRM) is the process of managing individuals in an organization to achieve goals that have been set effectively and efficiently. The function of HR is not only limited to administrative management, but also plays a strategic role in aligning human resource plans and policies with the company's business strategy in order to achieve the success of the organization as a whole (Diah et al., 2021). In its implementation, HR covers various aspects such as planning, employee development, performance evaluation, compensation, and the creation of harmonious working relationships. Human resources are considered the most valuable assets that are the main drivers in all organizational activities (Hall et al., 2022).

Furthermore, MSDM plays an important role in creating a long-term competitive advantage because employees are a strategic resource that cannot be replaced. Therefore, the alignment of the MSDM system with the organizational strategy is the main factor in improving organizational performance (Nurjaman et al., 2020). Human resource management is also based on the view that every employee is a human being who has potential and not just a means of production, so the approach involves psychological and social aspects (Adwishanty, 2021). With good management, human resources not only contribute to the achievement of organizational goals, but also to the development of long-term value and sustainability of the company (Tegar, 2019).

## 2.2. Work Discipline

Work discipline is an employee's attitude and behavior that shows compliance with the rules, norms, and work standards that have been set by the organization. Employees who have high discipline tend to work honestly, responsibly, and are oriented towards achieving the company's goals. Discipline is an important basis for improving performance and creating an orderly and productive work environment (Jepry & Mardika, 2020; Kurniawan, A. W, et al., 2023). Without good discipline, it is difficult for organizations to achieve goals effectively because discipline functions as a means of controlling behavior to be in line with company policies (Onsardi & Putri, 2020). Thus, discipline is not only about punishment, but also about the individual's awareness and commitment to obey the applicable rules (Hasibuan, 2019; Sutrisno, 2020).

Work discipline can be divided into three main types, namely preventive, remedial, and progressive disciplines. Preventive discipline focuses on encouraging employees to voluntarily obey regulations, while remedial discipline is applied to correct violations that have occurred. Progressive discipline is carried out by providing gradual sanctions for repeated violations to provide opportunities for employees to improve their behavior (Ramon, 2019; Fererius Hetlan Muhyadin, 2019). The level of discipline can be measured through several indicators, such as the frequency of attendance, vigilance at work, compliance with work guidelines and regulations, and work ethics (Sinambela, 2019). With the consistent application of discipline, organizations are able to create a work environment that is conducive, efficient, and results-oriented.

## 2.3. Work Performance

Work performance describes the results achieved by an employee in carrying out tasks in accordance with the responsibilities given, based on his or her abilities, experience, and commitment to work. Good performance reflects the effectiveness of efforts in utilizing individual knowledge, skills, and potential to achieve organizational goals (Fernando & Susanti, 2019). According to (Sutrisno, 2020; Suriani et al., 2023), performance is the level of a person's ability to carry out their work by considering competence and suitability to the demands of the position. Meanwhile, (Hasibuan, 2019) emphasized that performance is influenced by factors such as skills, motivation, and work attitude. Thus, work performance can be interpreted as a measure of employee success in achieving the targets and responsibilities given by the organization.

Job performance appraisals aim to provide a basis for decision-making related to promotion, compensation, training, and career development. Performance evaluation helps companies recognize employees' potentials and weaknesses so that they can increase productivity and work motivation (Hidayat et al., 2023; Sunyoto, 2019). In addition, the results of the assessment are also used to assess the effectiveness of the company's policies and human resource management systems. Indicators of work performance include aspects of achievement, discipline, creativity, cooperation, and responsibility (Nur Annisa et al., 2023). Overall, work performance appraisals function not only as an evaluation tool, but also as a means to develop employee performance and professionalism for organizational success.

## 2.4. Employee Performance

Employee performance etymologically comes from the word performance, which means the implementation or results of work. Performance can be interpreted as the result of a person's work in carrying out the assigned tasks in accordance with predetermined responsibilities and standards (Agus & Fadli, 2022; Sahabuddin, R, et al., 2024). . Performance includes not only the result, but also the process of how the work is done to

achieve the organization's goals. According to the American Psychological Association, employee performance is closely related to cognitive, motivational, affective, and psychological behavior aspects in the work environment that affect the work outcomes of individuals and organizations as a whole. Thus, employee performance is a tangible manifestation of individual contributions to the success of the organization that can be objectively measured based on applicable standards (Dipoatmodjo, T. S. P., 2025; Luthfiana, A. G. A, et al., 2023).

Employee performance styles are influenced by the leader's role in directing, motivating, and connecting between team members. As described in the journal *ResearchGate Leadership and Management*, leaders function as mediators between group opinions and collective information from various sources, as well as having authority in regulating team dynamics and influencing the behavior of its members. There are three styles of employee performance, namely: (1) a task-focused style, (2) a style that emphasizes teamwork, and (3) a result-oriented style. The performance indicators of employees include the quality of work, quantity of results, punctuality, effectiveness of the use of organizational resources, and independence in completing tasks. These five indicators are important benchmarks in assessing the extent to which employees are able to contribute to the achievement of organizational goals.

## **2.5. Organizational Culture**

Organizational culture is a set of values, beliefs, attitudes, systems, and rules that are shared by members of the organization to direct behavior and decision-making in the work environment. This culture becomes a guideline in carrying out organizational activities and forms a collective identity that distinguishes one organization from another. According to (Praharsyarendra, 2020; Nurhaliza et al., 2023), organizational culture has a positive influence on employee performance because it creates an environment conducive to collaboration and work motivation. In the context of the public sector, organizational culture also plays an important role in improving accountability and transparency, as explained in the international journal *Worktribe Durham Research*, that the pressure to improve performance reporting and public accountability is driving major changes in government financial management through the ideology of New Public Management (NPM). Thus, organizational culture plays a strategic role in creating stability, clarity of direction, and a shared commitment to achieve organizational goals.

The types of organizational culture can be divided into two, namely open and closed cultures. Open culture is characterized by active participation, trust, and transparent communication between members, while closed culture tends to be autocratic and power-centered. Qomaruddin (2019) groups organizational culture into four main types, namely collaboration (clan), creation (adhocracy), competition (market), and control (hierarchy). Each type has distinctive characteristics in how to work, communicate, and leadership. In addition, important elements in an organization's subculture include values and norms, communication styles, leadership, focus on innovation, reward systems, and adaptability to change. According to Hari (2019), organizational culture indicators include innovative aspects, attention to detail, result orientation, concern for employees, aggressive attitude at work, and work stability. All of these elements reflect the strength of organizational culture in shaping the behavior, work ethic, and competitiveness of the institution in a sustainable manner.

### 2.6. Conceptual Framework and Hypotheses

This frame of mind describes the relationship between work discipline and work performance on employee performance with organizational culture as a mediating variable. This model shows that organizational culture can strengthen the influence of discipline and work performance in improving employee performance optimally.

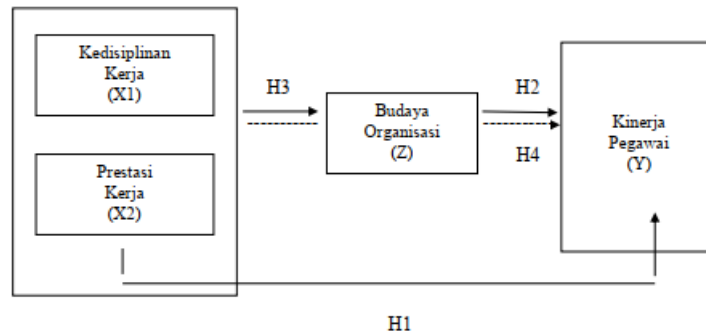

**Figure 1.** Conceptual Framework

Figure 1 shows a research framework that explains the relationship between Work Discipline (X1) and Work Performance (X2) to Employee Performance (Y), with Organizational Culture (Z) as a mediating variable. This model illustrates that improving discipline and work performance is expected to directly improve employee performance (H1). In addition, organizational culture also plays an important role in strengthening these relationships, both as a factor that directly affects employee performance (H2) and as a variable influenced by discipline and work performance (H3). Thus, organizational culture functions as a bridge that mediates the influence of discipline and work performance on employee performance (H4). Overall, this framework shows that a combination of discipline, achievements, and a strong organizational culture can create optimal and sustainable employee performance in an agency or organization.

### Research Hypothesis

The hypothesis of this research is described as follows:

- H1: There is an influence of work discipline and work performance on Employee Performance in the Work Unit of the Pamekasan Regency Transportation Office
- H2: There is an influence of organizational culture on Employee Performance in the Pamekasan Regency Transportation Office Work Unit
- H3: There is an influence of work discipline and work performance on organizational culture in the Work Unit of the Pamekasan Regency Transportation Office
- H4: There is an indirect influence of work discipline and work performance on Employee Performance through organizational culture in the Work Unit of the Pamekasan Regency Transportation Office

### 3. Methods

This study uses the Partial Least Square (PLS) method which is included in the variance-based Structural Equation Modeling (SEM) model. PLS is used for predictive purposes and is able to analyze constructs with reflective and formative indicators simultaneously (Ghozali, 2021). The variables in this study consisted of work discipline (X1) and work performance (X2) as independent variables, organizational culture (Z) as intervening variables, and employee performance (Y) as bound variables. This type of research is quantitative, with the population of all employees in the Pamekasan Regency Transportation Office work unit, which is

classified as an infinite population because the exact number is not known for sure. Samples are determined using purposive sampling techniques, which are sample selection based on certain criteria that are relevant to the research objectives. The number of samples used was 80 employees of the Pamekasan Regency Transportation Office who met criteria such as working period, understanding of main tasks and functions, and active involvement in organizational activities. Data was collected through interviews, literature studies, questionnaires, and documentation.

This research instrument uses the Likert scale as the main measurement tool to obtain quantitative data from respondents. This scale is used to measure respondents' attitudes, perceptions, and level of approval towards each statement submitted. Respondents were asked to rate their level of approval of the statement with five answer choices, namely: Strongly Agree (5), Agree (4), Neutral (3), Disagree (2), and Strongly Disagree (1). The operational definition of variables in this study includes three main constructs, namely work discipline (X1), work performance (X2), organizational culture (Z), and employee performance (Y). The variable of work discipline (X1) is measured through indicators of ability, reciprocity, employee involvement, and inherent supervision (Hasibuan, 2019). Employee performance variables (Y) include work quality, ability to complete tasks, and punctuality (Robbins, 2019). Meanwhile, organizational culture (Z) is measured by indicators of innovation, rigor, achievements, employee interests, productivity, and work stability (Sulaksono, 2019). Each indicator is translated into several statement items in the questionnaire that will be scored by respondents according to the Likert scale.

**Table 1.** Variable Operational Definition

Variable	Indicators	Items	Source
Work Discipline (X1)	Ability	Ability to influence the level of employee discipline	Hasibuan (2019:194)
	Discipline	Plays a role in determining discipline	
	Reply	Affecting employee discipline due to retaliation	
	Employee	Encourage employee discipline	
	Waskat	Beware of real and effective actions to prevent or influence employees	
Performance (Y)	Quality	Relating to generating tasks and work activities	Robbins (2019:260)
	Ability	Employees' ability to complete tasks	
	Timeliness	Performance activities and tasks are based on timeliness	
Organizational Culture (Z)	Innovative	Employees will pay attention	Sulaksono (2019:14)
	Thoroughness and Thoroughness	Describe precision and precision	
	Achievement Results	Supervision of a manager	
	Employee Interests	Teamwork	
	Work Productivity	Expertise qualifications	
	Job Stability	Employees maintain healthy conditions	

## 4. Results and Discussion

### 4.1. Overview of Research Objects

Pamekasan Regency is the most advanced district on Madura Island, East Java Province, with the highest human development index in Madura of 70.32 in 2023. This area has an area of 79,230 hectares, consisting of 13 sub-districts, 178 villages, and 11 sub-districts, with the government center in Pamekasan District. Geographically, Pamekasan is located in the middle of Madura Island on the strategic route of Sampang-Sumenep, with lowland conditions in the south and highlands in the north. The people use the eastern Madura dialect, which is known to be more refined and upholds local culture such as cow frequency and written batik. Economically, Pamekasan is growing rapidly through the agricultural sector—especially tobacco—as well as the service, manufacturing, and creative economy sectors, with economic growth of 4.96% in 2023. From a socio-political perspective, this area is relatively stable and religious, known as Gerbang Salam Regency, with a community that upholds Islamic values and a conducive political environment.

### 4.2. Distribution of Respondents' Answers

Based on the results of the analysis of the distribution of respondents' answers to the three research variables, a general overview was obtained that all variables were in the good category, which showed that respondents tended to agree with the statements made in the questionnaire. For the variables of Work Discipline (X1) and Work Achievement (X2), the average answer of the respondents was 3.76, indicating that employees have a good level of discipline and work performance. The item with the highest score (4.31) indicates that employees have a strong desire to work according to their skills, while the lowest score (3.58) illustrates the need for increased interaction between employees.

Meanwhile, the Employee Performance variable (Y) obtained an average of 3.69, which indicates that employee performance is at a good level. The highest score (4.18) indicates the importance of reward for work output, while the lowest score indicates the need for increased opportunities for interaction between employees to strengthen teamwork. The Organizational Culture variable (Z) has an average value of 3.28, indicating that the organizational culture is quite good but still needs strengthening. The item with the highest score (3.60) indicates that the employee is working to complete the work on time, while the item with the lowest score (2.80) indicates the need for improvement in the achievement of performance standards. Overall, the three variables showed positive results that supported the relationship between discipline, achievement, organizational culture, and employee performance improvement at the Pamekasan Regency Transportation Office.

### 4.3. Data Analysis

#### a) Outer Model Test Convergent Validity Test

Convergent validity is tested through the loading factor value with valid criteria if  $> 0.70$  (Chin, 1998, in Ghozali, 2011).

**Table 2.** Validity Test Results (Loading Factor)

Variable	Indicators	Loading	Information
Discipline & Work Performance	X1.1	0.783	Valid
	X1.2	0.942	Valid
	X1.3	0.753	Valid
	X1.4	0.893	Valid
	X1.5	0.948	Valid
Employee Performance	Y.1	0.920	Valid
	Y.2	0.914	Valid
	Y.3	0.764	Valid

	Y.4	0.840	Valid
Organizational Culture	Z.1	0.810	Valid
	Z.2	0.701	Valid
	Z.3	0.825	Valid
	Z.4	0.753	Valid

Source: data processed, 2025

The entire loading factor value > 0.7, so all indicators are declared valid. Furthermore, the Discriminant Validity test shows that the cross loading value shows that each indicator has a higher correlation to its construct compared to other constructs. Thus, all variables meet the criteria of discriminant validity (Hussein, 2019). The Reliability Test shows that all variables show a Composite Reliability value of > 0.70, which means that this research instrument is reliable and consistent in measuring the construct in question

b) Test inner model (structural model)

The internal evaluation of the model aims to see the relationship between latent variables with the R<sup>2</sup> and Q<sup>2</sup> indicators.

Coefficient of Determination (R<sup>2</sup>)

The R<sup>2</sup> value indicates how much the exogenous variable is able to explain the endogenous variable.

**Table 3.** Value of Coefficient of Determination (R<sup>2</sup>)

Endogenous Variable	R <sup>2</sup>	Interpretation
Organizational Culture (Z)	0.589	Strong
Employee Performance (Y)	0.633	Strong

Source: SmartPLS Data Processing (2025)

R<sup>2</sup> values of 0.589 and 0.633 indicate that the model has strong predictive capabilities, where more than 58% and 63% of the variation can be explained by exogenous variables.

Predictive Relevance (Q<sup>2</sup>)

The value of Q<sup>2</sup> = 0.851, which means that the model has very good predictive relevance because it > 0.35 (Ghozali & Latan, 2019). This means that 85.1% of the data diversity can be explained by the model, while the remaining 14.9% is explained by factors other than the model.

c) Hypothesis Test

Based on the results of the evaluation of the outer model and inner model, all constructs are eligible for hypothesis testing using the bootstrapping method in SmartPLS 3.3.3 (Figure 2). The test was carried out on the direct and indirect influence between latent variables.

Live Testing

Direct influence tests were carried out on the H1, H2, and H3 hypotheses with t-statistical criteria of > 2.01 and p-value < 0.05 showing significant influence.

**Table 4.** Path Coefficients Test Results

Code	Relationship Pathway	Original Sample (O)	t-Statistic	p-Value	Information
H1	Discipline & Work Performance → Employee Performance	0.233	1.727	0.082	Insignificant
H2	Discipline & Work Performance → Organizational Culture	0.767	16.614	0.000	Significant
H3	Organizational Culture → Employee Performance	0.600	5.649	0.000	Significant

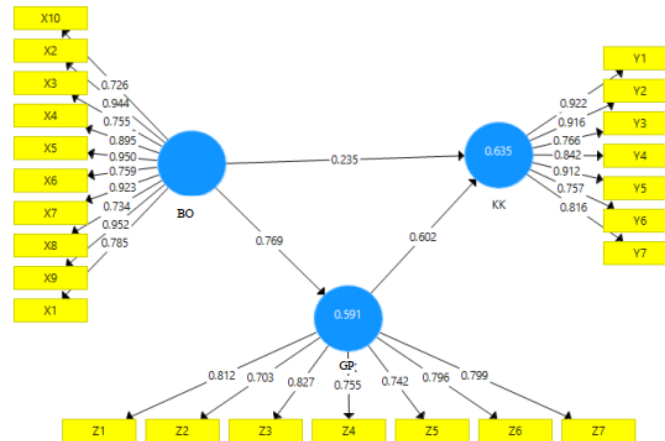

Figure 2. Model PLS

Interpretation of the results:

H1 was rejected, because the p-value > 0.05, showing that Discipline and Work Performance had no significant effect directly on Employee Performance.

H2 was accepted, showing a positive and significant influence of Discipline & Work Performance on Organizational Culture.

H3 was accepted, showing that Organizational Culture has a significant positive effect on Employee Performance.

Indirect Influence Testing

The indirect influence test (H4) was conducted to see the role of Organizational Culture as a mediating variable between Discipline & Work Performance (X) and Employee Performance (Y).

Table 5. Indirect Effects Test Results

Code	Indirect Relationship Pathway	Original Sample (O)	t-Statistic	p-Value	Information
H4	Discipline & Work Performance → Organizational Culture → Employee Performance	0.461	5.432	0.000	Significant

The test results showed that Organizational Culture significantly mediated the relationship between Discipline & Work Performance to Employee Performance, so H4 was accepted. This means that indirect influence is stronger than direct influence, and organizational culture plays a role as a partial mediation variable.

4.4. The Influence of Work Discipline and Work Achievement on Employee Performance

The results of the study show that Work Discipline and Work Achievement do not have a significant positive influence on Employee Performance. This condition can be caused by a lack of interaction between employees and the application of discipline that is not consistent. According to (Setiawan & Nugroho, 2021), employee performance is not only influenced by discipline and achievement, but also by motivation factors and adequate organizational support. Therefore, improving performance requires a more comprehensive approach, not limited to the discipline aspect alone.

#### **4.5. The Influence of Work Discipline and Work Performance on Organizational Culture**

Work Discipline and Work Achievement have been proven to have a positive and significant effect on Organizational Culture. This shows that disciplined and outstanding employees will form positive and productive organizational values. In line with the research of (Pudjarti et al., 2019), organizational culture develops when employees show high commitment and discipline in carrying out tasks. Thus, placing employees according to their skills and giving awards for work achievements is an effective strategy to strengthen organizational culture.

#### **4.6. The Influence of Organizational Culture on Employee Performance**

Organizational Culture has a positive and significant influence on Employee Performance. A strong culture encourages employees to work with clear, responsible, and results-oriented standards. According to (Melinda, 2019), a healthy organizational culture fosters a sense of belonging and collaborative spirit between employees so that performance increases sustainably. This shows that a good work culture is an important foundation in improving the effectiveness and efficiency of employee performance.

#### **4.7. The Influence of Work Discipline and Work Achievement on Employee Performance through Organizational Culture**

Organizational Culture plays a role as a partial mediator in the relationship between Work Discipline and Work Performance to Employee Performance. This means that discipline and work achievement can improve performance if supported by a positive work culture. This is in line with the findings of (Prasmara, 2019), which states that organizational culture is able to strengthen the effects of discipline and achievement on performance through the mechanism of forming mutual value and employee commitment to the organization's vision. Therefore, management needs to strengthen an organizational culture that supports collaboration, reward, and professionalism.

### **5. Conclusion**

Based on the results of the research and discussions that have been carried out, it can be concluded that work discipline and work performance do not have a significant effect on improving employee performance in the Pamekasan Regency Transportation Office Work Unit. However, these two variables have been proven to improve organizational culture, so that the better the discipline and work performance of employees, the stronger the organizational culture that is formed. A good organizational culture is ultimately able to improve employee performance because employees are encouraged to work according to their standards and responsibilities. In addition, organizational culture also plays a role as a mediating variable that strengthens the influence of work discipline and work performance on employee performance. Based on these results, the Pamekasan Regency Transportation Office is expected to continue to improve and maintain employee performance by providing appropriate awards and rotating jobs based on individual skills so that employees feel comfortable and productive at work. The researcher is then advised to expand the research object in different agencies or sectors with similar variables, so that the results can enrich the study of the relationship between work discipline, work performance, organizational culture, and employee performance in various organizational contexts.

## 6. References

- Adwishanty, N. (2021). The Influence of Human Resource Management on Employee Performance. *Journal of Management and Business*, 8(2), 145–156. <https://doi.org/10.32528/jmb.v8i2.982>
- Agus, S., & Fadli, R. (2022). Employee Performance Analysis Based on Motivation and Work Discipline. *Scientific Journal of Economics and Business*, 9(3), 215–226. <https://doi.org/10.47266/jieb.v9i3.1345>
- Aula, F., Prasetyo, A., & Rahman, A. (2022). Competency-Based Human Resource Management. *Indonesian Journal of Administration and Business*, 10(1), 44–59. <https://doi.org/10.54099/jabi.v10i1.1623>
- Diah, N., Lestari, P., & Hidayat, R. (2021). Human Resource Management in a Strategic Perspective. *Journal of Management Science*, 17(1), 33–47. <https://doi.org/10.23917/jim.v17i1.10433>
- Dipoatmodjo, T. S. P. (2025). Experiencing Change: A Phenomenological Study of Employee Adaptation to AI-Driven Digital Transformation in a Tech Company. *International Journal of Humanity Advance, Business & Sciences (IJHABS)*, 3(1), 25–34. <https://doi.org/10.59971/ijhabs.v3i1.448>
- Fererius, H. M. (2019). Analysis of Work Discipline and Its Influence on Employee Performance. *Scientific Journal of Human Resource Management*, 7(2), 120–132. <https://doi.org/10.31219/osf.io/nyqvt>
- Fernando, Y., & Susanti, D. (2019). Factors Affecting Employee Work Performance. *Journal of Economics and Management*, 5(1), 87–99. <https://doi.org/10.31933/jem.v5i1.321>
- Ghozali, I. (2021). *Partial Least Square: Concepts, Techniques, and Applications of SmartPLS 3.0 for Empirical Research*. Semarang: Diponegoro University Press. <https://doi.org/10.13140/RG.2.2.15713.35683>
- Hari, A. (2019). Organizational Culture and Its Influence on Performance. *Journal of Business Administration*, 6(3), 12–25. <https://doi.org/10.33369/jab.v6i3.8741>
- Hasibuan, M. S. P. (2019). *Human Resource Management (Revised Edition)*. Jakarta: PT Bumi Aksara.
- Hidayat, R., Wijaya, S., & Lestari, N. (2023). Employee Work Performance Assessment in the Digital Era. *Journal of Management and Entrepreneurship*, 11(2), 73–89. <https://doi.org/10.24912/jmk.v11i2.12145>
- Jepry, H., & Mardika, I. (2020). The Influence of Discipline and Motivation on Employee Performance. *Journal of Economics & Management*, 18(1), 112–120. <https://doi.org/10.35457/jem.v18i1.843>
- Jufrizen, J. (2020). Company Culture and Its Influence on Employee Performance. *Scientific Journal of Management and Business*, 7(2), 101–113. <https://doi.org/10.30596/jimb.v7i2.4954>
- Kurniawan, A. W., Rauf, D. I., & Arif, H. M. (2023). Efforts To Improve Performance In Managing Regional Finance Through Human Resources, Organizational Culture And Organizational Commitment. *Jurnal Pengabdian Masyarakat (JUMAS)*, 1(1), 33–38. <https://doi.org/10.59971/jumper.v1i1.26>
- Luthfiana, A. G. A., Nurman, Dipoatmodjo, T. S., Natsir, U. D., & Burhanuddin. (2023). The Influence of Work Motivation and Discipline on Employee Performance at PT. PLN (Persero) UP3 North Makassar. *International Journal of Humanity Advance, Business*

- & Sciences (IJHABS), 1(3), 109–114. <https://doi.org/10.59971/ijhabs.v1i3.72>
- Melinda, T. (2019). The Influence of Organizational Culture on Employee Performance. *Journal of Management and Business Sciences*, 10(2), 56–68. <https://doi.org/10.33087/ekonomis.v10i2.147>
- Nur Annisa, F., Pratiwi, N., & Sari, L. (2023). Analysis of Employee Performance Indicators. *Journal of Economics and Business*, 12(1), 45–58. <https://doi.org/10.55678/jeb.v12i1.2389>
- Nurhaliza, Wardhana Haeruddin, M. I., Ruma, Z., Akbar, A., & Natsir, U. D. (2023). The Effect of Compensation and Work Stress on Employee Performance in the Sales Force Section of PT. World Innovative Telecommunication Makassar. *International Journal of Humanity Advance, Business & Sciences (IJHABS)*, 1(2), 57–66. <https://doi.org/10.59971/ijhabs.v1i2.36>
- Nurjaman, D., Hidayat, A., & Putra, R. (2020). MSDM Strategy for Competitive Advantage. *Journal of Management and Business*, 9(1), 77–89. <https://doi.org/10.34010/jmb.v9i1.3212>
- Onsardi, O., & Putri, E. (2020). Work Discipline and Its Influence on Productivity. *Journal of Administrative Sciences*, 9(3), 134–142. <https://doi.org/10.31933/jia.v9i3.2111>
- Praharsyarendra, A. (2020). Organizational Culture and Its Impact on Employee Performance. *Journal of Management and Business*, 17(2), 99–109. <https://doi.org/10.32528/jmb.v17i2.1749>
- Qomaruddin, M. (2019). Analysis of Organizational Culture Type on Work Effectiveness. *Journal of Business Administration*, 8(1), 15–26. <https://doi.org/10.35797/jab.v8i1.529>
- Ramon, D. (2019). Implementation of Preventive and Corrective Work Discipline. *Journal of Economics and Management*, 4(2), 65–77. <https://doi.org/10.31219/osf.io/8msxv>
- Robbins, S. P. (2019). *Organizational Behavior* (17th ed.). Pearson Education. <https://doi.org/10.4324/9780134729664>
- Sahabuddin, R., Selamanda, A. R., Sari, E. P., Ramli, M. F., & Arif, H. M. (2024). Assessing Financial Performance as a Mediator in the Corporate Governance-Company Value Relationship: Insights from the IDX Banking Sector. *International Journal of Humanity Advance, Business & Sciences (IJHABS)*, 2(1), 31-44.
- Sutiawan, A. (2021). Human resource development and its Impact on Productivity. *Journal of Applied Economics & Business*, 9(3), 176–189. <https://doi.org/10.35912/jebt.v9i3.1152>
- Sulaksono, A. (2019). Organizational Culture Dimension in Increasing Work Productivity. *Journal of Applied Business Administration*, 7(1), 13–22. <https://doi.org/10.31219/osf.io/fhtwc>
- Sutrisno, E. (2020). *Human Resource Management*. Jakarta: Kencana Prenada Media Group.
- Tegar, M. (2019). *Human Resource Management: Theory and Application*. Yogyakarta: Deepublish.
- Triana Melinda Sinaga. (2020). Work Discipline and Employee Performance. *Journal of Business Administration*, 11(2), 99–109. <https://doi.org/10.31219/osf.io/ksdbm>